

# Chapter - 9

## Some Applications of Trigonometry

### Height and Distance

#### Introduction

Astronomers have used trigonometry to calculate distances from the earth to the planets and stars.

Trigonometry is used to measure the height of a building or a mountain.

Trigonometry is also used to construct maps and to determine the position of an island in relation to the longitudes and latitudes.

#### Heights and Distances

#### Heights and Distances



<b>Horizontal Level</b>	The horizontal level is the line parallel to the ground from the eye level of the observer.
<b>Line of Sight</b>	The line of sight is the line drawn from the eye of an observer to the point in the object viewed by the observer
<b>Angle of Elevation</b>	The angle of elevation of the point viewed is the angle formed by the line of sight with the horizontal when the point being viewed is above the horizontal level, that is, when the head is raised to look at objects.
<b>Angle of Depression</b>	The angle of depression of a point being viewed is the angle formed by the line of sight with the horizontal when the point is below the horizontal level, that is when the head is lowered to look at the object.

If we have to find the height of the tower without actually measuring it, then we need the following informations,

The distance AB, of the observer from the foot of the tower.

The angle of elevation,  $\angle BAC$

Now we will use trigonometric ratios to find the value of BC (Height of the tower)

• So, we see that when we use trigonometric ratios, tan or cot we are using the two values that we know, that is, AB and  $\angle BAC$ .

•  $\tan A = \frac{BC}{AB}$  or  $\cot A = \frac{AB}{BC}$ , which on solving give us BC.

Example: A wall casts a shadow of length  $2\sqrt{3}$  m on the ground, when the sun's elevation is  $60^\circ$

Find the height of the wall.

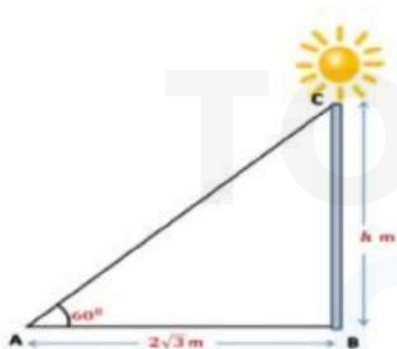

Let  $BC = h$  m be the height of the wall and  $AB = 2\sqrt{3}$  m be the length of the shadow.

$\angle BAC = 60^\circ$  is the Angle of elevation.

In right-angled triangle  $\Delta ABC$

$$\tan 60^\circ = \frac{BC}{AB} \Rightarrow \sqrt{3} = \frac{BC}{2\sqrt{3}}$$

$$BC = \sqrt{3} \times 2\sqrt{3} = 2 \times 3 = 6 \text{ m}$$

Example: If the height and the length of the shadow of a man are the same, then find the angle of elevation of the Sun.

Let BC be the height of the man and AB be the length of the shadow of the man.

Let the angle of elevation of the sun be  $\theta$

We know that the height and the length of the shadow of a man are equal.

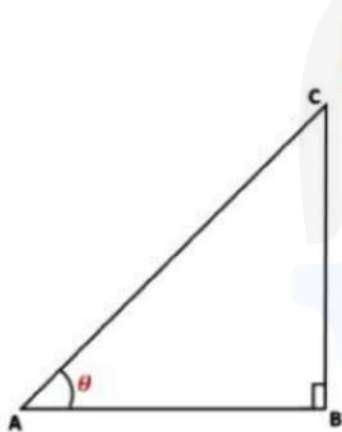

$$\therefore AB = BC$$

$$\tan \theta = \frac{BC}{AB} \Rightarrow \tan \theta = \frac{BC}{BC} \quad (\because AB = BC)$$

$$\tan \theta = 1 \Rightarrow \tan \theta = \tan 45^\circ$$

$$\theta = 45^\circ$$

Example: A ladder, leaning against a wall, makes an angle of  $30^\circ$  with the horizontal. If the height of the wall is 2.5 m, then find the length of the ladder.

Let AC = l m be the length of the ladder.

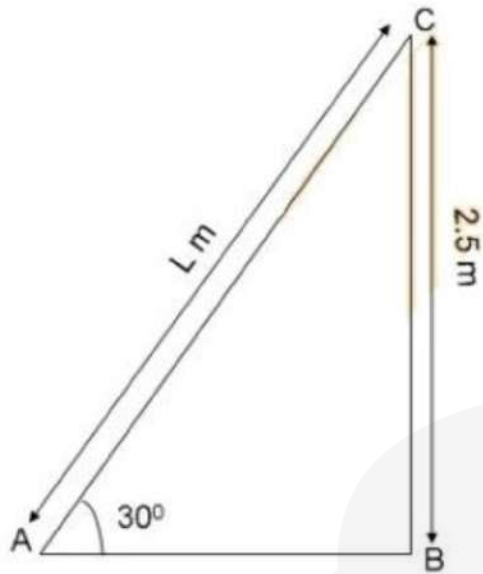

Angle

In right-angled  $\Delta ABC$ ,

$$\sin 30^\circ = \frac{BC}{AC} \Rightarrow \frac{1}{2} = \frac{2.5}{l}$$

$$l = 5 \text{ m}$$

Example: Two poles of equal heights are standing opposite each other on either side of the road, which is 80 m wide. From a point between them on the road, the angles of elevation of the top of the poles are  $60^\circ$  and  $30^\circ$ , respectively. Find the height of the poles and the distances of the point from the poles.

(REFERENCE: NCERT)

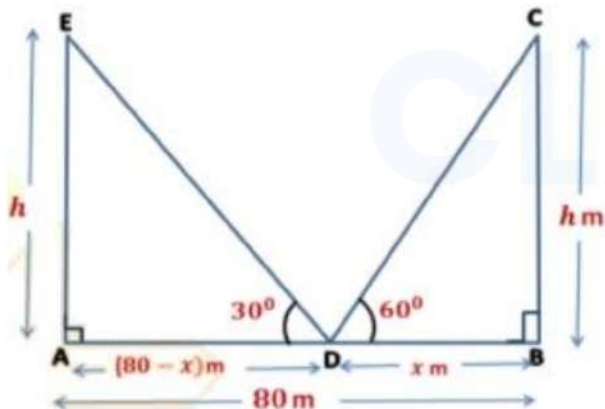

Here,

Width of the road = 80 m

Let the height of the two poles be h m.

Let D be the point on AB such that angle of elevations from point D are  $\angle ADE = 30^\circ$  and  $\angle BDE = 60^\circ$

Let  $BD = x$  m

Then,  $AD = AB - BD = (80 - x)$  m

In right angled  $\Delta DAE$ ,  $\tan \theta = \frac{AE}{AD} = \frac{h}{80 - x} \Rightarrow \tan 30 = \frac{h}{(80 - x)}$

$$\tan 30^\circ = \frac{h}{(80 - x)} \Rightarrow \frac{1}{\sqrt{3}} = \frac{h}{(80 - x)} \quad (\tan 30^\circ = \frac{1}{\sqrt{3}})$$

$$\Rightarrow \sqrt{3}h = 80 - x$$

$$\Rightarrow \sqrt{3}h + x = 80 \rightarrow \text{Eq 1}$$

In right-angled  $\Delta DBC$ ,  $\tan \theta = \frac{BC}{BD} = \frac{h}{x} \Rightarrow \tan 60 = \frac{h}{x}$

$$\tan 60^\circ = \frac{h}{x} \Rightarrow \sqrt{3} = \frac{h}{x} \quad (\tan 60^\circ = \sqrt{3})$$

$$h = \sqrt{3}x \rightarrow \text{Eq 2}$$

On putting  $h = \sqrt{3}x$  in Eq 1, we get

$$\sqrt{3}(\sqrt{3}x) + x = 80 \Rightarrow 3x + x = 80 \Rightarrow 4x = 80 \Rightarrow x = 20 \text{ m}$$

On putting  $x = 20$  m in Eq 2 we get,

$$h = 20\sqrt{3} \text{ m}$$

Now,  $AD = (80 - 20) = 60$  m

Height of the poles is  $20\sqrt{3}$  m and the distances of the point D from the poles are 60 m and 20 m.

Example: The angle of depression of a car standing on the ground, from the top of a 100 m high tower, is  $30^\circ$ .

Find the distance of the car from the base of the tower.

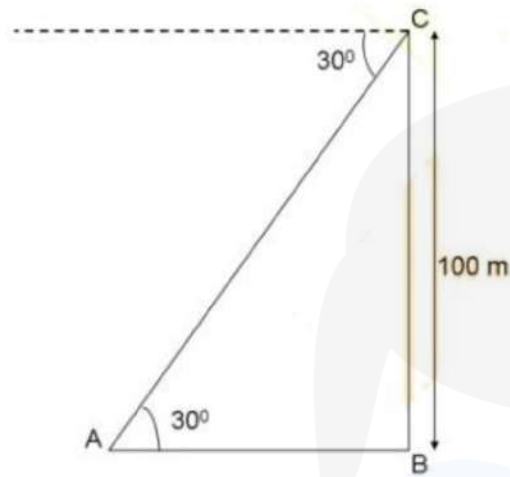

Let AB be the distance of the car from the base of the tower.

The height of the tower, BC is 100 m.

Angle of Depression,  $\angle DCA = 30^\circ$

Now,  $\angle DCA = \angle CAB = 30^\circ$  (Alternate Angles)

Now, in right-angled  $\Delta ABC$ ,

$$\tan 30^\circ = \frac{BC}{AB} \Rightarrow \frac{1}{\sqrt{3}} = \frac{100}{AB} \quad (\tan 30^\circ = \frac{1}{\sqrt{3}})$$

$$\Rightarrow AB = 100\sqrt{3} \text{ m}$$

Therefore, the distance between the car and the base of the tower is  $100\sqrt{3}$  m

Example: A 1.2 m tall girl spots a balloon moving with the wind in a horizontal line at a height of 88.2 m from the ground. The angle of elevation of the balloon from the eyes of the girl at any instant is  $60^\circ$ . After some time, the

angle of elevation reduces to  $30^\circ$ . Find the distance travelled by the balloon during the interval.

(REFERENCE: NCERT)

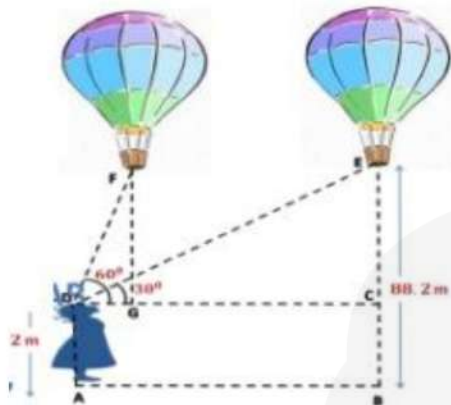

Here,

Height of the girl,  $AD = 1.2$  m

$FH = EB = 88.2$  m is the height of the balloon from AB.

The angles of elevation at the eye of the girl are,

$\angle FDC = 60^\circ$  and  $\angle EDC = 30^\circ$

Now,  $FG = EC = EB - BC$

$FG = 88.2 - 1.2 = 87$  m

Let  $DG = xm$  and  $GC = x$  m be the distance travelled by the balloon. In right-angled  $\triangle FGD$

$$\tan 60^\circ = \frac{FG}{DG} \Rightarrow \sqrt{3} = \frac{87}{x}$$

$$x = \frac{87}{\sqrt{3}} \text{ m} \rightarrow \text{Eq 1}$$

In right-angled  $\triangle ECD$

$$\tan 30^\circ = \frac{EC}{CD} \Rightarrow \frac{1}{\sqrt{3}} = \frac{87}{x+y} \quad (\tan 30^\circ = \frac{1}{\sqrt{3}} \text{ and } CD = CG + GD)$$

$$x + y = 87\sqrt{3} \rightarrow \text{Eq 2}$$

On putting  $x = \frac{87}{\sqrt{3}}$  in Eq 2

$$\frac{87}{\sqrt{3}} + y = 87\sqrt{3} \Rightarrow y = 87\sqrt{3} - \frac{87}{\sqrt{3}} = \frac{87 \times 3 - 87}{\sqrt{3}} = \frac{87(3-1)}{\sqrt{3}}$$

$$= \frac{87 \times 2}{\sqrt{3}}$$

$$= \frac{174}{\sqrt{3}} \times \frac{\sqrt{3}}{\sqrt{3}} = \frac{174 \times \sqrt{3}}{3} = 58\sqrt{3} \text{ m}$$

Therefore, the distance traveled by the balloon during the interval is  $58\sqrt{3}$  m.

Example: A straight highway leads to the foot of a tower. A man standing at the top of the tower observes a car at an angle of depression of  $30^\circ$ , which is approaching the foot of the tower with a uniform speed. Six seconds later, the angle of depression of the car is found to be  $60^\circ$ . Find the time taken by the car to reach the foot of the tower from this point.

(REFERENCE: NCERT)

Let  $h$  be the height of the tower. The observer is standing at point  $D$  of the tower and observes the car at an angle of depression of  $30^\circ$ . After 6 seconds, the angle of depression of the car is  $60^\circ$ .

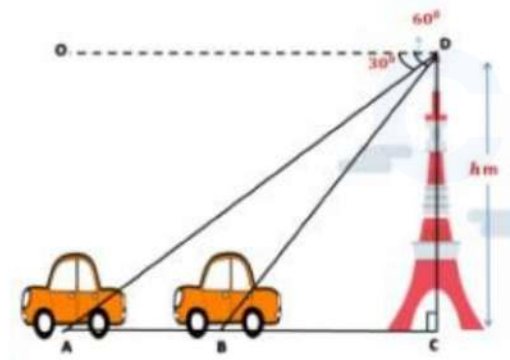

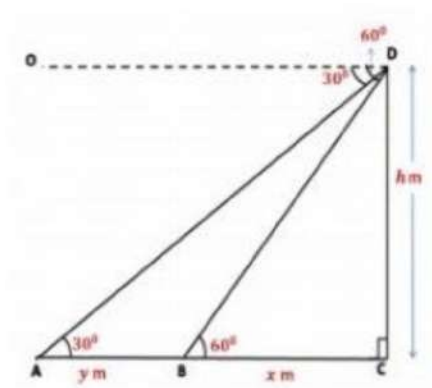

Here,  $\angle ODA = 30^\circ$  and  $\angle ODB = 60^\circ$

Now,  $\angle ODA = \angle DAC = 30^\circ$

(Alternate Angles)

$\angle ODB = \angle DBC = 60^\circ$  (Alternate Angles)

Let  $AB = y$  m and  $BC = x$  m

In  $\Delta ACD$

$$\tan 30^\circ = \frac{DC}{AC} \Rightarrow \frac{1}{\sqrt{3}} = \frac{h}{x+y} \Rightarrow x+y = \sqrt{3}h \rightarrow \text{Eq1}$$

In  $\Delta BCD$

$$\tan 60^\circ = \frac{DC}{BC} \Rightarrow \sqrt{3} = \frac{h}{x} \Rightarrow h = \sqrt{3}x \rightarrow \text{Eq2}$$

Putting the value of  $h$  in Eq 1 we get,

$$x+y = \sqrt{3} \times \sqrt{3}x \Rightarrow x+y = 3x \Rightarrow 2x = y \rightarrow \text{Eq2}$$

Let the speed of the car be  $v$  km/s. Now the car moves from A to B in 6 seconds.

$$\therefore \text{Time} = \frac{\text{distance}}{\text{speed}} = \frac{y}{v} = 6 = \frac{y}{v} = y = 6v$$

On putting  $y = 6v$  in Eq 1 we get,

$$2x = 6v \Rightarrow x = 3v$$

$$\therefore \text{Time} = \frac{x}{v} = \frac{3v}{v} = 3s$$

Therefore, the car moves from point B to C in 3 s.

